



Designation: D217 – 10



Designation: 50/88

Standard Test Methods for Cone Penetration of Lubricating Grease¹

This standard is issued under the fixed designation D217; the number immediately following the designation indicates the year of original adoption or, in the case of revision, the year of last revision. A number in parentheses indicates the year of last reapproval. A superscript epsilon (ϵ) indicates an editorial change since the last revision or reapproval.

This standard has been approved for use by agencies of the U.S. Department of Defense.

1. Scope*

1.1 These test methods cover four procedures for measuring the consistency of lubricating greases by the penetration of a cone of specified dimensions, mass, and finish. The penetration is measured in tenths of a millimetre.

NOTE 1—The National Lubricating Grease Institute (NLGI)² classified greases according to their consistency as measured by the worked penetration. The classification system is as follows:

NLGI Consistency Number	Worked Penetration Range, 25°C (77°F)
000	445 to 475
00	400 to 430
0	355 to 385
1	310 to 340
2	265 to 295
3	220 to 250
4	175 to 205
5	130 to 160
6	85 to 115

1.1.1 The procedures for unworked, worked, and prolonged worked penetration are applicable to greases having penetrations between 85 and 475, that is, to greases with consistency numbers between NLGI 6 and NLGI 000. An undisturbed penetration test, described in **Appendix X1**, is similar to the unworked penetration test.

1.1.2 The block penetration procedure is applicable to greases that are sufficiently hard to hold their shape. Such greases usually have penetrations below eighty-five tenths of a millimetre.

1.1.3 Unworked penetrations do not generally represent the consistency of greases in use as effectively as do worked penetrations. The latter are usually preferred for inspecting lubricating greases.

¹ These test methods are the jurisdiction of ASTM Committee D02 on Petroleum Products and Lubricants and are the direct responsibility of Subcommittee D02.G0.02 on Consistency and Related Rheological Tests. In the IP, these test methods are under the jurisdiction of the Standardization Committee. These test methods were adopted as a joint ASTM-IP standard in 1969.

Current edition approved May 1, 2010. Published June 2010. Originally approved in 1925. Last previous edition approved in 2007 as D217-02(2007). DOI: 10.1520/D0217-10.

² National Lubricating Grease Institute, 4635 Wyandotte St., Kansas City, MO 64112-1596.

1.2 None of the four procedures is considered suitable for the measurement of the consistency of petrolatums by penetration. Test Method **D937** should be used for such products.

1.3 The dimensions of the equipment described in these test methods are given in inches and fractions of an inch. These units were retained because a vast body of data has been obtained using equipment with the dimensions shown. Metric equivalency tables are provided with each figure. Temperatures and other dimensions are given in the preferred SI units; the values shown in parentheses are provided for information.

1.4 *This standard does not purport to address all of the safety concerns, if any, associated with its use. It is the responsibility of the user of this standard to establish appropriate safety and health practices and determine the applicability of regulatory limitations prior to use.*

2. Referenced Documents

2.1 *ASTM Standards:*³

- D937 Test Method for Cone Penetration of Petrolatum
- D1403 Test Methods for Cone Penetration of Lubricating Grease Using One-Quarter and One-Half Scale Cone Equipment

3. Terminology

3.1 *Definitions:*

3.1.1 *consistency, n*—of lubricating grease, the degree of resistance to movement under stress.

3.1.1.1 *Discussion*—The term consistency is used somewhat synonymously with penetration. Generally, consistency refers to the worked penetration of a grease.

3.1.2 *lubricant, n*—any material interposed between two surfaces that reduces the friction or wear between them.

3.1.3 *lubricating grease, n*—a semi-fluid to solid product of a dispersion of a thickener in a liquid lubricant.

³ For referenced ASTM standards, visit the ASTM website, www.astm.org, or contact ASTM Customer Service at service@astm.org. For *Annual Book of ASTM Standards* volume information, refer to the standard's Document Summary page on the ASTM website.

*A Summary of Changes section appears at the end of this standard

3.1.3.1 *Discussion*—The dispersion of the thickener forms a two-phase system and immobilizes the liquid lubricant by surface tension and other physical forces. Other ingredients are commonly included to impart special properties.

3.1.4 *penetrometer, n*—an instrument that measures the consistency or hardness of semiliquid to semisolid materials by measuring the depth to which a specified cone or needle under a given force falls into the material.

3.1.4.1 *Discussion*—In this test method, either a standard penetrometer 6.2 or an optional penetrometer cone A1.3 can be used to determine the consistency of lubricating greases. The penetration force is determined by the mass of the cone and the shaft.

3.1.5 *thickener, n*—in lubricating grease, a substance composed of finely divided particles dispersed in a liquid lubricant to form the product's structure.

3.1.5.1 *Discussion*—The thickener can be fibers (such as various metallic soaps) or plates or spheres (such as certain non-soap thickeners) which are insoluble or, at most, only very slightly soluble in the liquid lubricant. The general requirements are that the solid particles be extremely small, uniformly dispersed, and capable of forming a relatively stable, gel-like structure with the liquid lubricant.

3.2 *Definitions of Terms Specific to This Standard:*

3.2.1 *block penetration, n*—of lubricating grease, the penetration at 25°C (77°F) determined on the freshly prepared face of a cube cut from a sample that is sufficiently hard to hold its shape.

3.2.2 *penetration, n*—of lubricating grease, the depth that the standard cone (see A1.1), enters the sample when released to fall under its own weight for 5 s.

3.2.3 *penetrometer, n*—an instrument (see Fig. 1) designed to measure the depth to which the standard cone falls into the grease.

3.2.4 *prolonged worked penetration, n*—of lubricating grease, the penetration of a sample after it has been worked more than 60 double strokes in a standard grease worker at a temperature of 15 to 30°C (59 to 86°F).

3.2.4.1 *Discussion*—After the prescribed number of double strokes, the worker and contents are brought to 25°C (77°F), worked an additional 60 double strokes, and penetrated without delay.

3.2.5 *unworked penetration, n*—of lubricating grease, the penetration at 25°C (77°F) of a sample that has received only minimum disturbance in transferring to a grease worker cup or dimensionally equivalent rigid container.

3.2.6 *worked penetration, n*—of lubricating grease, the penetration at 25°C (77°F), without delay, of a sample after 60 double strokes in a standard grease worker.

3.2.7 *working, n*—of lubricating grease, the subsection of a sample to the shearing action of the standard grease worker.

4. Summary of Test Method

4.1 For unworked penetration, the sample is brought to 25 ± 0.5°C (77 ± 1°F) using a temperature bath. The sample is then transferred with as little manipulation as possible into a

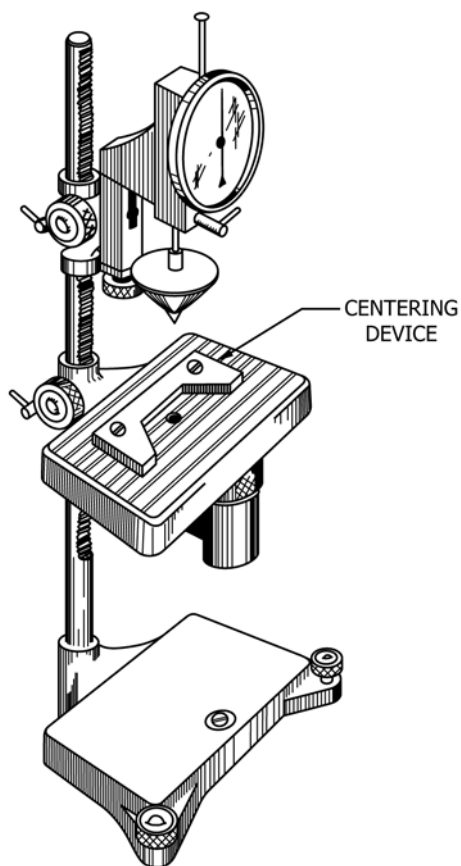

FIG. 1 Penetrometer

worker cup (or other suitable container), if not placed there before the temperature stabilization step. The cone assembly of the penetrometer is released and allowed to drop freely into the grease for 5 ± 0.1 s. Three determinations are made and averaged to give the reported result.

4.2 For worked penetration, the sample is brought to 25 ± 0.5°C (77 ± 1°F) and placed in the worker cup. The sample is subjected to 60 double strokes in the grease worker. The penetration is determined immediately by releasing the cone assembly from the penetrometer and allowing the cone to drop freely into the grease for 5 ± 0.1 s. Three determinations are made and averaged to give the reported result.

4.3 For prolonged worked penetration, the sample is placed in the worker cup and subjected to a predetermined number of double strokes in the grease worker. Following completion of the prolonged working, the grease and worker assembly are brought to 25 ± 0.5°C (77 ± 1°F) and the grease is worked an additional 60 double strokes in the grease worker. The penetration is determined immediately by releasing the cone assembly from the penetrometer and allowing the cone to drop freely into the grease for 5 ± 0.1 s. Three determinations are made and averaged to give the reported result.

4.4 For block penetration, a cube of the grease is prepared by slicing off a thin layer using the grease cutter. The cube of grease is brought to 25 ± 0.5°C (77 ± 1°F) and placed on the penetrometer table with the prepared face upward. The penetration is determined by releasing the cone assembly from the

penetrometer and allowing the cone to drop freely into the grease for 5 ± 0.1 s. Three determinations are made and averaged to give the reported result.

5. Significance and Use

5.1 These cone penetration tests not only evaluate the consistency of lubricating greases over the full range of NLGI numbers from 000 to 6, but also evaluate the consistency of stiff greases having penetration numbers less than 85. In contrast, Test Method **D937** is aimed at petrolatums and Test Method **D1403** uses less precise one-quarter and one-half scale equipment intended for use when the sample quantity is limited.

5.2 Cone penetration test results provide one measure of the consistency of a grease. Worked penetration results are required to determine to which NLGI consistency grade a grease belongs. Undisturbed penetration results provide a means of evaluating the effect of storage conditions on grease consistency.

5.3 Although no correlation has been developed between cone penetration results and field service, the cone penetrations obtained by the four procedures are widely used for specification purposes, such as in users' material specifications and suppliers' manufacturing specifications.

6. Apparatus

6.1 *Penetrometer*, in accordance with **A1.1**. The instrument shall be capable of indicating depth in tenths of a millimetre. A sketch of a generic penetrometer is shown in **Fig. 1**.

6.2 *Standard Penetrometer Cone*, in accordance with **A1.2**, is suitable for all penetrations. An optional penetrometer cone, in accordance with **A1.3**, is suitable only for penetrations less than 400. The optional cone should not be used to measure the penetration of 00 and 000 grade greases.

6.3 *Grease Worker*, comprising a grease cup, cover, and plunger assembly, in accordance with **A1.4**, constructed for either manual or mechanical operation.

6.3.1 *Grease Worker Drive, Manual*, in accordance with **A1.5**, which allows for working the grease at a rate of 60 ± 10 double strokes per minute.

6.3.2 *Grease Worker Drive, Motorized*, in accordance with **A1.6**, which allows for working the grease at a rate of 60 ± 10 double strokes per minute. This apparatus is essential for the working step of the prolonged worked penetration procedure.

6.4 *Grease Cutter*, in accordance with **A1.7**, is used for preparation of samples for block penetration.

6.5 *Temperature Bath*, capable of controlling the bath temperature at $25 \pm 0.5^\circ\text{C}$ ($77 \pm 1^\circ\text{F}$) and designed to bring the assembled grease worker to test temperature conveniently. Examples of suitable temperature baths include a water bath, air bath, constant temperature test room, or a temperature-controlled metal block. If a water bath is to be used for samples for unworked penetration, means should be provided for protecting the grease surface from water and for maintaining the air above the sample at test temperature. An air bath is preferred for bringing block greases to test temperature, but a tightly sealed container placed in a water bath will suffice.

6.6 *Spatula*, corrosion-resistant, having a stiff blade nominally 32 mm (1.25 in.) wide and at least 150 mm (6 in.) long.

6.7 *Temperature-Measuring Device*, with a sheath length of approximately 200 mm (8 in.) and a sheath diameter of approximately 3.7 mm (0.145 in.) (small enough to fit through the vent cock). The temperature range of the device should be wide enough to allow it to be immersed in grease at approximately 38°C (100°F) without damage. The scale should have small enough divisions (or digital resolution) to allow the user to read $\pm 0.5^\circ\text{C}$ ($\pm 1^\circ\text{F}$). A spacer can be applied to the upper portion of the sheath to hold the tip just above the perforated plate of the grease worker and in the bulk of the sample (see **A1.3**).

6.8 *Overflow Ring (optional)*, in accordance with **A1.8**, is a useful device for catching grease scraped from the sample surface as well as any grease forced by the penetrometer cone to overflow from the cup. This grease can be returned to the worker cup for subsequent testing.

7. Reagents and Materials

7.1 *Appropriate Volatile Gum-free Solvent*, for example, light petroleum naphtha.

7.2 *Cloth or Paper Wiper*, for wiping grease from the penetrometer cone. The wiper should be soft, so as not to scratch the cone.

8. Sampling

8.1 *Sample Size*—Sufficient sample (at least 0.45 kg (1.1 lb)) to overfill the cup of the standard grease worker is required. If the sample size is insufficient and penetration ranges from NLGI 0 to 4, use Test Method **D1403**.

8.1.1 For block penetration, obtain a sufficient size sample of the grease, which must be hard enough to hold its shape, to permit cutting from it a 50-mm (2-in.) cube as a test specimen.

8.2 *Sample Preparation*—Samples are prepared for the various cone penetration test methods as follows:

8.2.1 *Unworked Penetration*—Prior to performing the test, the grease sample (if necessary, in a suitable container or in the worker cup) and the test equipment (worker cup and cone) must all be at a standard temperature of $25 \pm 0.5^\circ\text{C}$ ($77 \pm 1^\circ\text{F}$). This can be achieved by the use of a temperature bath (Section 6.5) or a combination of different temperature baths. It is important to allow sufficient time for the grease and test equipment to reach $25 \pm 0.5^\circ\text{C}$ ($77 \pm 1^\circ\text{F}$). Additional time will be required to achieve a consistent temperature of $25 \pm 0.5^\circ\text{C}$ ($77 \pm 1^\circ\text{F}$) if the sample is larger than 0.45 kg (1.1 lb), or if the initial sample temperature differs from 25°C by more than about 8°C (15°F). If the grease sample and equipment are already at the correct temperature before the sample is placed into the worker cup, there is no need to further stabilize the sample once it has been placed in the cup. Testing may proceed if the specimen is at a uniform temperature of $25 \pm 0.5^\circ\text{C}$. Transfer the specimen, preferably in one lump, to overfill the cup of the grease worker or other container. Make this transfer in such a manner that the grease will be worked as little as possible.



FIG. 2 Preparing Sample for Penetration Measurement

a thermometer through the vent cock so that its tip is in the center of the grease. Place the assembled worker in the temperature bath maintained at $25 \pm 0.5^\circ\text{C}$ ($77 \pm 1^\circ\text{F}$) (**Note 2**) until the temperature of the worker and its contents is $25 \pm 0.5^\circ\text{C}$ as indicated by the thermometer. If the initial sample temperature differs from 25°C by more than about 8°C (15°F), or if an alternative method of bringing the sample to 25°C is used, allow sufficient additional time to ensure that the specimen is at $25 \pm 0.5^\circ\text{C}$ before proceeding. Testing may proceed when the specimen is at a uniform temperature of $25 \pm 0.5^\circ\text{C}$. Remove the worker from the bath. If a water bath was used, wipe any excess water from the outer surfaces of the worker. Remove the thermometer and close the vent cock.

8.2.2.1 Working—Subject the grease to 60 full (63 to 71.5 mm ($2\frac{7}{16}$ to $2\frac{13}{16}$ in.)) double strokes of the plunger, completed in about 1 min, and return the plunger to its top position. Open the vent cock, remove the cover and plunger, and return to the cup as much of the grease clinging to the plunger as can readily be removed.

NOTE 2—If it is desired to immerse the worker into a water bath, above the joint between the cup and cover, take care that the joint is watertight in order to prevent the entrance of water to the worker.

8.2.2.2 Preparing Sample for Measurement—Jar the cup sharply on the bench or floor and pack the grease down with a spatula to fill the holes left by the plunger and to remove any air pockets (**Note 3**). Scrape off the excess grease extending over the rim, creating a flat surface, by moving the blade of the spatula, held inclined toward the direction of motion at an angle of approximately 45° , across the rim of the cup (**Fig. 2**), retaining the portion removed (**Note 4**).

NOTE 3—The jarring should be only as vigorous as required to remove the entrapped air without splashing the specimen from the cup. In performing these operations, a minimum of manipulation should be used, as any agitation of the grease may have the effect of increasing the working beyond the specified 60 strokes.

NOTE 4—Particularly when testing soft greases, retain the grease removed from the cup in scraping to provide a full cup for subsequent tests. Keep the outside of the rim of the cup clean so that the grease forced by the penetrometer cone to overflow the cup may be returned to the cup prior to preparing the specimen for the next test.

8.2.3 Prolonged Worked Penetration—Fill a clean grease worker cup and assemble the worker as described in **8.2.2.2**. Subject the grease specimen to the prescribed number of double strokes (**Note 5**). Immediately after the working is concluded, use a temperature bath to bring the test specimen to $25 \pm 0.5^\circ\text{C}$ ($77 \pm 1^\circ\text{F}$) within 1.5 h. Remove the grease and worker from the temperature bath and subject the grease to a further 60 full (63 to 71.5 mm ($2\frac{7}{16}$ to $2\frac{13}{16}$ in.)) double strokes of the plunger, completed in about 1 min, and return the plunger to its top position. Open the vent cock, remove the cover and plunger, and return to the cup as much of the grease clinging to the plunger as can readily be removed.

8.2.3.1 Preparing Sample for Measurement—Jar the cup sharply on the bench or floor and pack the grease down with a spatula to fill the holes left by the plunger and to remove any air pockets (**Note 3**). Scrape off the excess grease extending over the rim, creating a flat surface, by moving the blade of the spatula, held inclined toward the direction of motion at an

8.2.1.1 Preparing Sample for Measurement—Jar the cup to drive out trapped air and pack the grease with the spatula, with as little manipulation as possible, to obtain a cupful without air pockets. Scrape off the excess grease extending over the rim, creating a flat surface, by moving the blade of the spatula, held inclined toward the direction of motion at an angle of approximately 45° , across the rim of the cup (**Fig. 2**). This excess grease will be retained to repair the surface for the second and third determinations. Do not perform any further leveling or smoothing of the surface throughout the determination of unworked penetration and determine the measurement immediately.

8.2.1.2 The penetrations of soft greases are dependent upon the diameter of the container. Therefore, greases having unworked penetrations greater than 265 should be tested in containers having the same diameter limitations as those of the worker cup. The results on greases having penetrations less than 265 are not significantly affected if the diameter of the container exceeds that of the worker cup.

8.2.2 Worked Penetration—Prior to performing the test, the grease sample (if necessary, in a suitable container or in the worker cup) and the test equipment (worker cup, plunger and cone) must all be at a standard temperature of $25 \pm 0.5^\circ\text{C}$ ($77 \pm 1^\circ\text{F}$). This can be achieved by the use of a temperature bath (Section 6.5) or a combination of different temperature baths. Additional time will be required to achieve a consistent temperature of $25 \pm 0.5^\circ\text{C}$ ($77 \pm 1^\circ\text{F}$) if the sample is larger than 0.45 kg (1.1 lb), or if the initial sample temperature differs from 25°C by more than about 8°C (15°F). If the grease sample and equipment are already at the correct temperature before the sample is placed into the worker cup, there is no need to further stabilize the sample once it has been placed in the cup. Transfer sufficient specimen to the cup of the clean grease worker to fill it heaping full (mound up about 13 mm (0.5 in.) at the center), avoiding the inclusion of air by packing with the spatula. Jar the cup from time to time as it is being packed to remove any air inadvertently entrapped. Assemble the worker and, with the vent cock open, depress the plunger to the bottom.

If an air bath or water bath is used to bring grease and equipment to $25 \pm 0.5^\circ\text{C}$ ($77 \pm 1^\circ\text{F}$) after assembly, then insert

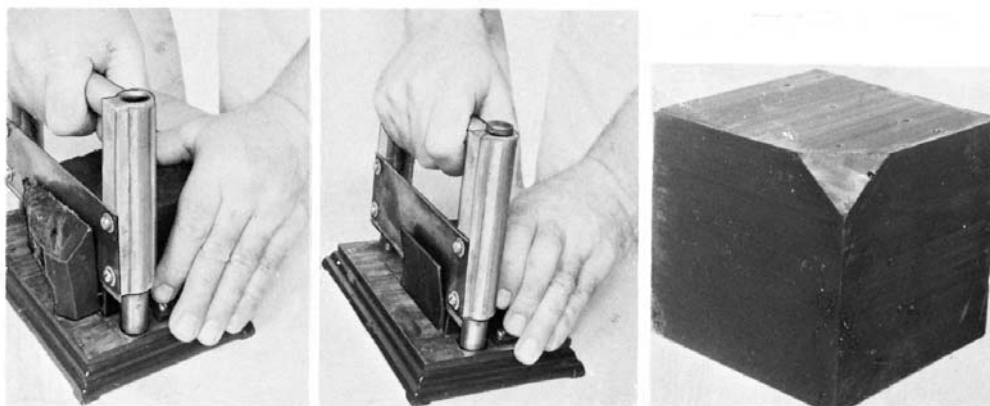

FIG. 3 Preparing Block Sample for Penetration Measurement

angle of approximately 45°, across the rim of the cup (Fig. 2), retaining the portion removed (Note 4).

NOTE 5—In order to minimize leakage during working, special attention should be paid to the seal in the worker cover.

8.2.3.2 *Temperature*—Maintain the temperature of the room used for the test within the range from 15 to 30°C (59 to 86°F). No further control of the worker temperature is necessary; but, before starting the test, the grease should have been in the room for sufficient time to bring its temperature within the range from 15 to 30°C.

8.2.4 *Block Grease*—By means of the specified grease cutter, cut as a test specimen from the sample at room temperature a cube about 50 mm (2 in.) on the edge (Fig. 3(a)). While holding this specimen so that the unbeveled edge of the cutter is toward it (Fig. 3(b)), slice off a layer about 1.5 mm ($\frac{1}{16}$ in.) in thickness from each of the three faces adjacent to a single corner, which can be truncated for identification (Fig. 3(c) and Note 6). Take care not to touch those portions of the newly exposed faces which are to be used for testing or to set a prepared face against the base plate or guide of the cutter. Bring the temperature of the prepared specimen to $25 \pm 0.5^\circ\text{C}$ ($77 \pm 1^\circ\text{F}$) by placing it in a temperature bath maintained at 25°C (77°F) for at least 1 h. If the initial sample temperature differs from 25°C by more than about 8°C (15°F), or if an alternative method of bringing the sample to 25°C is used, allow sufficient additional time to ensure that the specimen is at $25 \pm 0.5^\circ\text{C}$ ($77 \pm 1^\circ\text{F}$) before proceeding.

NOTE 6—The testing of three faces is intended to equalize in the final value the effect of fiber orientation in testing fibrous greases. Smooth-textured, nonfibrous greases can be tested on one face only, when agreed upon between the interested parties.

9. Preparation of Apparatus

9.1 *Cleaning Penetrometer Cone*—Clean the penetrometer cone carefully before each test with a soft cloth or paper wiper. The wiper can be dampened with an appropriate volatile gum-free solvent, when necessary, to remove any grease remaining on the cone. The solvent should have no effect on the cone surface. While cleaning, do not rotate the cone, as this can cause wear on the release mechanism. Bending of the cone shaft can be avoided by holding the cone securely in its raised position while cleaning.

9.2 *Cleaning Penetrometer Shaft*—The penetrometer shaft should be cleaned periodically with a soft cloth or paper wiper dampened with an appropriate volatile gum-free solvent to remove any oil, grease, or dirt buildup. Foreign materials on the penetrometer shaft can cause drag on the shaft assembly, possibly causing erroneous results.

9.3 Any other cleaning or adjustments to the apparatus should be done in accordance with the equipment manufacturer's recommendations.

10. Calibration and Standardization

10.1 Proper operation of a grease penetrometer can be checked by running periodic tests with a grease of known consistency. NLGI² reference grease has been found to be suitable for this purpose, since multiple laboratories run tests on this material to generate the data reported for it. Data on this material is provided by NLGI with the purchase of the grease. Alternatively, the same grease sample (different specimens) can be tested on multiple penetrometers and the results obtained can be compared.

11. Procedure

11.1 *Unworked Penetration*—Place the cup on the penetrometer table, making certain that it cannot teeter. Set the mechanism to hold the cone in the zero position, and adjust the apparatus carefully so that the tip of the cone just touches the surface at the center of the test specimen. Watching the shadow of the cone tip, from a low angle with backlighting, is an aid to accurate setting. For greases with penetrations over 400, the cup must be centered to within 0.3 mm (0.01 in.) of the tip of the cone. One way to center the cup accurately is to use a centering device (Fig. 1). Release the cone shaft rapidly, and allow it to drop for 5.0 ± 0.1 s. The release mechanism should not drag on the shaft. Lock the shaft in position at the end of the 5-s period. Gently depress the indicator shaft until stopped by the cone shaft and read the penetration from the indicator.

11.1.1 *Additional Tests*—After the first measurement, use the excess grease (retained from the initial surface preparation) to replace the grease lost to the cone, jarring the cup to remove any trapped air and repairing the surface of the specimen as described in 8.2.1.1 and shown in Fig. 2. It is important to minimize working of the specimen. Clean the penetrometer

cone to remove the adhered grease as described in 9.1. After the second measurement, repeat this procedure to obtain a third measurement. Make a total of three tests on the same specimen (using the same cup), and report the average of the three tests, to the nearest 0.1 mm, as the unworked penetration of the specimen.

11.2 *Worked Penetration*—Determine the penetration of the specimen in accordance with 11.1.

11.2.1 *Additional Tests*—After the first measurement is made, replace the grease lost to the penetration cone with some of the grease sample previously removed with the spatula (8.2.2.2 and Note 4). Then remove any trapped air and repair the surface of the specimen as described in 8.2.2.2 and shown in Fig. 2. Clean the penetrometer cone to remove the adhered grease as described in 9.1. After the second measurement, repeat this procedure to obtain a third measurement. Report the average of the three tests, to the nearest 0.1 mm, as the worked penetration of the specimen.

11.3 *Prolonged Worked Penetration*—Determine the penetration of the specimen in accordance with 11.1.

11.3.1 *Additional Tests*—After the first measurement is made, replace the grease lost to the penetration cone with some of the grease sample previously removed with the spatula (Section 8.2.3.1 and Note 4). Then remove any trapped air and repair the surface of the specimen as described in Section 8.2.3.1 and shown in Figure 2. Clean the penetrometer cone to remove the adhered grease as described in Section 9.1. After the second measurement, repeat this procedure to obtain a third measurement. Report the average of the three tests, to the nearest 0.1 mm, as the prolonged worked penetration of the specimen.

11.4 *Block Penetration*—Place the test specimen on the penetrometer table with one of the prepared faces upward, and press it down by the corners to make it rest level and firmly on the table so that it cannot teeter during the test. Set the mechanism to hold the cone in the zero position, and adjust the apparatus carefully so that the tip of the cone just touches the surface at the center of the test sample. Determine the penetration in accordance with 11.1. Make a total of three tests on the exposed face of the specimen, locating the tests at least 6 mm (¼ in.) from the edge and as far apart as possible without impinging on any touched portion, air hole, or other apparent flaw in the surface. If the result of one of these tests differs from the others by more than three units, make additional tests until three values agreeing within three units are obtained. Average these three values for the face being tested.

11.4.1 *Additional Tests*—Repeat the procedure described in 11.4 on each of the other prepared faces of the specimen. Report one third of the sum of the averages for the three faces, to the nearest 0.1 mm as the block penetration of the specimen.

12. Report

12.1 Report the following information:

12.1.1 *Unworked Penetration*—Report the average value obtained in 11.1.1 as the unworked penetration of the grease under test.

TABLE 1 Repeatability and Reproducibility

Penetration	Penetration Range	Repeatability, One Operator and Apparatus	Reproducibility, Different Operators and Apparatus
Unworked	85 to 475	8 units	22 units
Worked	130 to 475	7 units	23 units
Prolonged worked	130 to 475	8 units ^A	29 units ^A
Block	under 85	7 units	11 units

^A Determined at 100 000 double strokes within 15 to 30°C (59 to 86°F) ambient temperature range.

12.1.2 *Worked Penetration*—Report the average value obtained in 11.2.1 as the worked penetration of the grease under test.

12.1.3 *Prolonged Worked Penetration*—Report the average value obtained in 11.3.1 as the prolonged worked penetration of the grease under test. The number of double strokes to which the grease was subjected during the prolonged working shall also be reported.

12.1.4 *Block Penetration*—Report the average value obtained in 11.4.1 as the block penetration of the grease under test.

13. Precision and Bias⁴

13.1 *Precision*—The precision of these test methods has been obtained in accordance with the requirements of Committee D02, RR:D02-1007, Manual on Determining Precision Data for ASTM Test Methods on Petroleum Products and Lubricants.⁵

13.2 The precision of these test methods as determined by statistical examination of interlaboratory results is as follows:

13.2.1 *Repeatability*—The difference between two test results obtained by the same operator with the same apparatus under constant operating conditions on identical test material would, in the long run, in the normal and correct operation of the test method, exceed the values in Table 1 in only one case in twenty.

13.2.2 *Reproducibility*—The difference between two single and independent results obtained by different operators working in different laboratories on identical test material would, in the long run, in the normal and correct operation of the test method, exceed the values in Table 1 in only one case in twenty.

13.3 *Bias*—The procedure in Test Methods D217 for measuring cone penetration of lubricating greases has no bias because the value of cone penetration is defined only in terms of these test methods.

14. Keywords

14.1 consistency; grease; lubricating grease; penetration; penetrometer; worked penetration

⁴ Supporting data have been filed at ASTM International Headquarters and may be obtained by requesting Research Report RR:D02-1689.

⁵ Supporting data have been filed at ASTM International Headquarters and may be obtained by requesting Research Report RR:D02-1007.

(Mandatory Information)
A1. APPARATUS

A1.1 *Penetrometer*, similar to the instrument illustrated in Fig. 1, designed to measure in tenths of a millimetre the depth to which the standard (or optional) cone falls into the grease. The cone assembly or the table of the penetrometer shall be adjustable to enable accurate placement of the tip of the cone on the level surface of the grease while maintaining a zero reading on the indicator. When released, the cone should fall without appreciable friction. Both the penetrometer shaft and the rack engaging the measuring dial should be at least 62.0 mm in length. If only penetrations less than 400 are to be measured, the penetrometer may be designed such that, when released, the cone falls for at least 40.0 mm. The tip of the cone should not hit the bottom of the sample container. The instrument shall be provided with leveling screws and a spirit level to maintain the cone shaft in a vertical position.

A1.1.1 *Automatic Penetrometers*, which include such devices as timers, electrical release mechanisms, digital depth indicators, and contact sensors are permitted, so long as the results obtained with such instruments are shown to fall within the precision in accordance with 13.2.

A1.2 *Standard Cone*, for measuring penetrations up to 475, consisting of a conical body of magnesium or other suitable material with detachable, hardened steel tip, shall be constructed to conform to the tolerances in accordance with Fig. A1.1. The total mass of the cone shall be 102.5 ± 0.05 g and that of its movable attachments shall be 47.5 ± 0.05 g; the attachments shall consist of a rigid shaft having a mechanical stop at its upper end and suitable means, at the lower end, for engaging the cone. The interior construction of the cone can be modified to achieve the specified weight, provided that the general contour and weight distribution are not altered. The outer surface of the cone is to be polished to a smooth finish. A surface finish in the range from 0.10 to $1.12 \mu\text{m}$ (4 to $44 \mu\text{in.}$) root mean square (RMS) has been found to have no measurable effect on penetration results.

A1.3 *Optional Cone*, for measuring penetrations up to 400, consisting of a conical body of brass or corrosion-resistant steel with detachable, hardened steel tip, shall be constructed to conform to the tolerances shown in Fig. A1.2. The total mass

of the cone shall be 102.5 ± 0.05 g and that of its movable attachments shall be 47.5 ± 0.05 g; the attachments shall consist of a rigid shaft having a mechanical stop at its upper end and suitable means, at the lower end, for engaging the cone. The interior construction of the cone can be modified to achieve the specified weight, provided that the general contour and weight distribution are not altered. The outer surface of the cone is to be polished to a smooth finish. A surface finish in the range from 0.18 to $1.50 \mu\text{m}$ (7 to $59 \mu\text{in.}$) RMS has been found to have no measurable effect on penetration results.

A1.4 *Grease Worker*, consisting of a grease cup, cover, and plunger assembly and conforming to the dimensions given in Fig. A1.3. The dimensions not shown may be altered and other methods of fastening the lid and securing the worker can be used. The worker can be constructed for either manual or mechanical operation.

A1.5 *Grease Worker Drive, Manual*, similar to that shown in Fig. A1.4. The design must be such that a rate of 60 ± 10 strokes per minute with a minimum length of 63 mm ($2 \frac{7}{16}$ in.), can be maintained.

A1.6 *Grease Worker Drive, Motorized*, similar to that shown in Fig. A1.5. The design must be such that a rate of 60 ± 10 strokes per minute with a minimum length of 63 mm ($2 \frac{7}{16}$ in.), can be maintained. The mechanical grease worker must be provided with a presetting counter to permit the apparatus to be automatically stopped after any required number of double strokes up to 99 999.

A1.7 *Grease Cutter*, having a sharp, rigidly mounted, beveled blade, shall be essentially as shown in Fig. A1.6. It is necessary that the blade be straight and sharpened, as shown.

A1.8 *Overflow Ring (optional)*, conforming in principal to the illustration in Fig. A1.3 is a useful aid for returning displaced grease to the worker cup. The overflow ring shall be positioned at least 13 mm ($\frac{1}{2}$ in.) below the rim of the cup while making a penetration measurement. A rim 13 mm high is helpful.

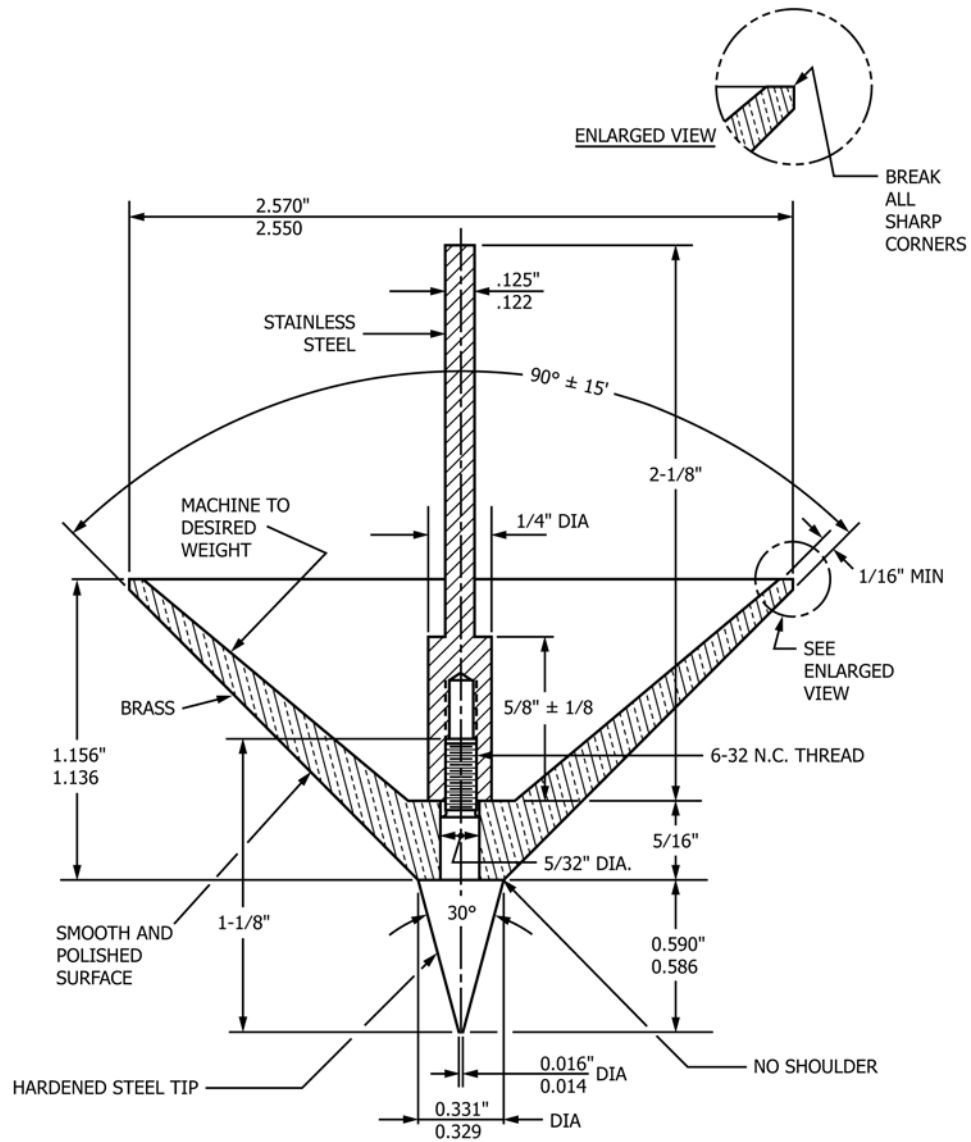

Inches	Millimetres ^A	Metric Equivalents	Inches	Millimetres ^A
1/16	1.6		0.125	3.18
5/32	4.0		0.329	8.36
1/4	5.4		0.331	8.40
5/16	7.9		0.586	14.85
5/8 ± 1/8	15.9 ± 3.2		0.590	14.98
1 1/8	28.6		1.136	28.85
2 1/2	54.0		1.158	29.36
0.014	0.36		2.550	64.75
0.016	0.40		2.570	65.28
0.122	3.10			

^A Not necessarily direct conversions.

NOTE 1—Tolerances on all fractional dimensions to be 1/16 in. (1.6 mm).

NOTE 2—The total weight of the cone shall be 102.5 ± 0.05 g, and the total weight of its movable attachments shall be 47.5 ± 0.05 g.

NOTE 3—Surface finish to be cleaned and polished. See A1.3.

FIG. A1.2 Optional Penetrometer Cone

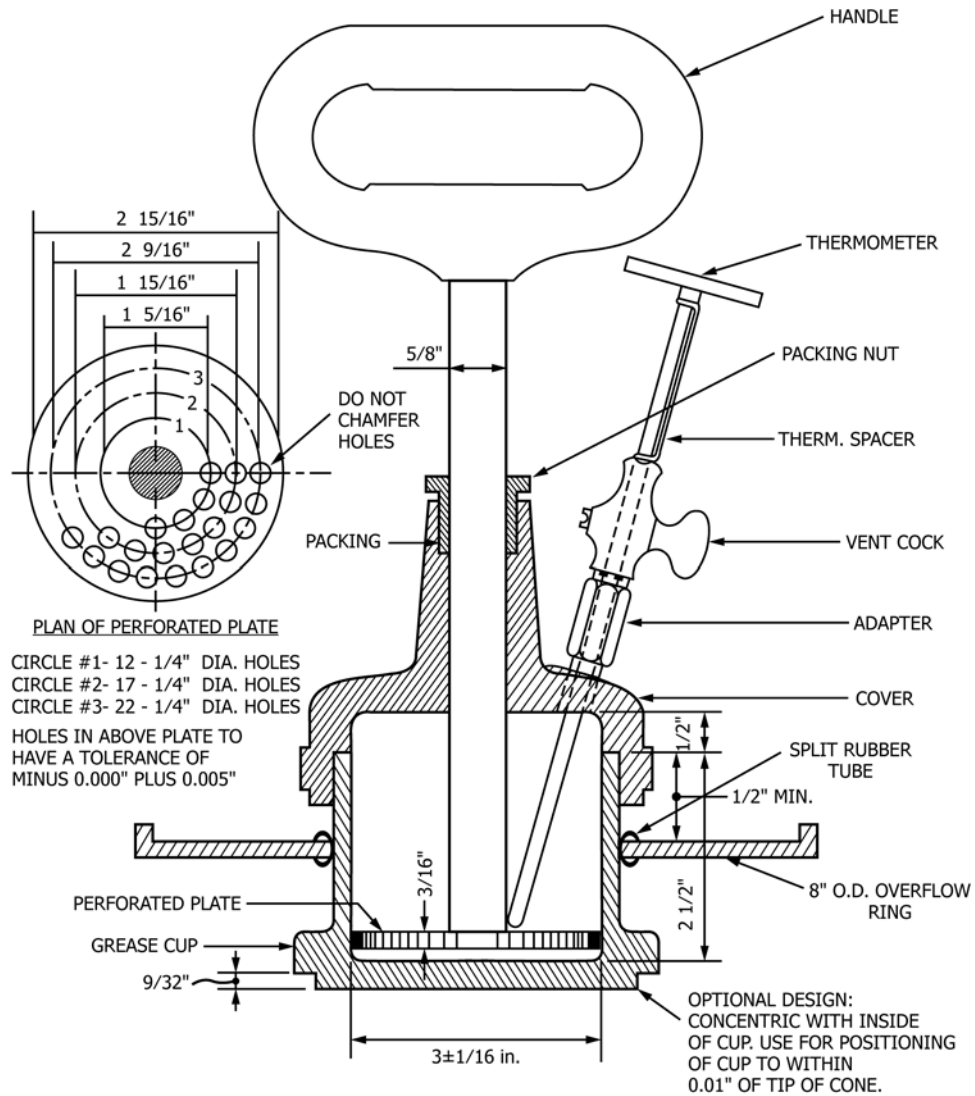

Inches		Metric Equivalents	
Inches	Millimetres ^A	Inches	Millimetres ^A
3/16	4.8	29/16	65.1
1/4	6.4	215/16	74.6
9/32	7.0	8	203.0
1/2	12.7	0.005	0.13
5/8	15.9	0.01	0.25
15/16	33.34	3	76.2
115/16	49.2		
21/2	63.5		

^A Not necessarily direct conversions.

NOTE 1—The handle, shaft, and perforated plate make up the plunger assembly.

NOTE 2—Tolerances on all fractional dimensions to be 1/16 in. (1.6 mm) unless otherwise specified.

FIG. A1.3 Grease Worker

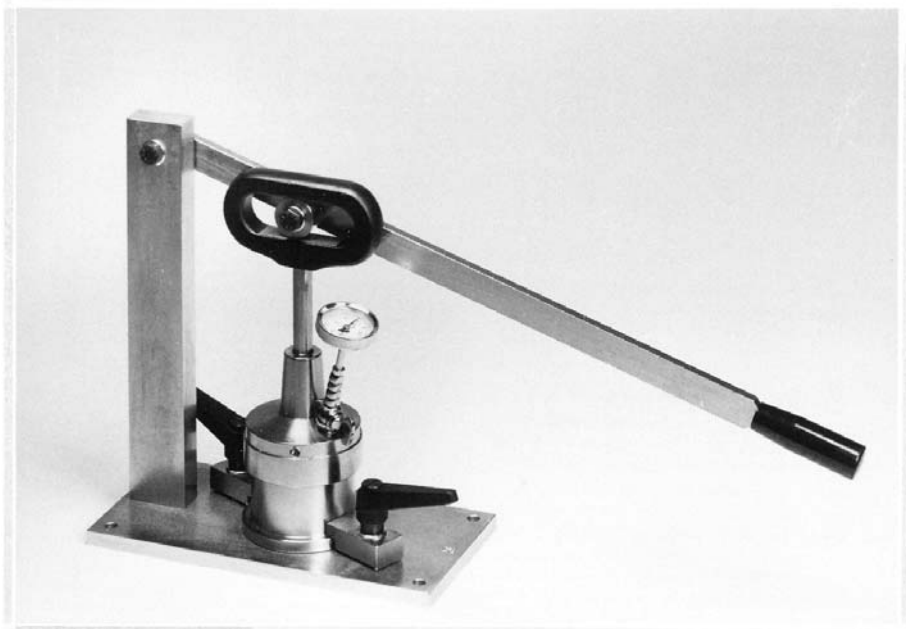

FIG. A1.4 Manual Grease Worker

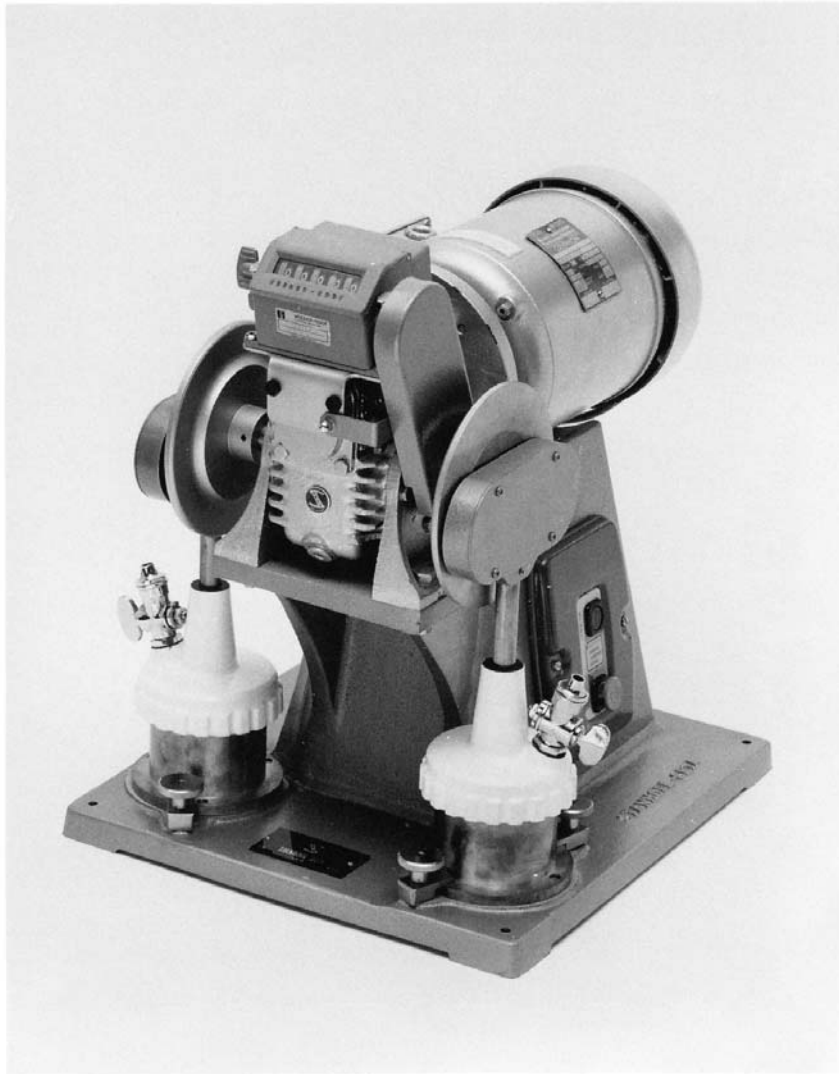
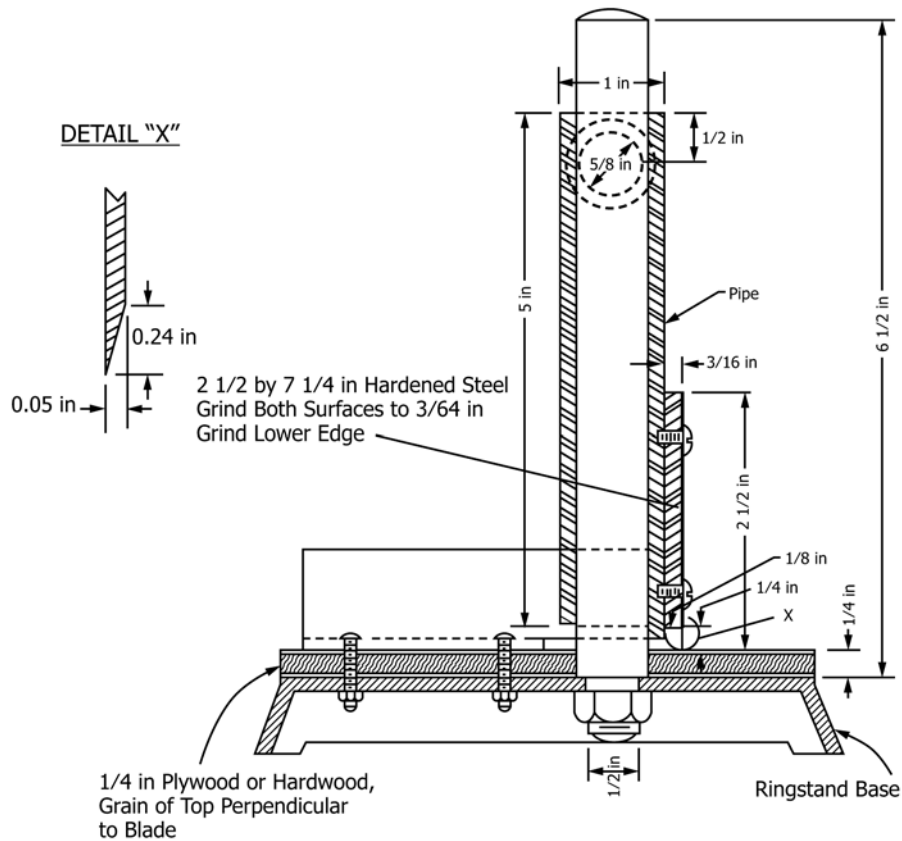

FIG. A1.5 Mechanical Grease Worker



Inches		Metric Equivalents	
Inches	Millimetres ^A	Inches	Millimetres ^A
3/64	1.2	2 1/2	63.5
1/2	3.2	5	127.0
3/16	4.8	6 1/2	165.0
1/4	6.4	7 1/4	184.2
1/2	12.7	Detail X	
5/8	15.9	0.05	1.2
1	25.4	0.24	6.0

^A Not necessarily direct conversions.

FIG. A1.6 Grease Cutter

APPENDIX

(Nonmandatory Information)

X1. UNDISTURBED PENETRATION

X1.1 Undisturbed penetration is defined as the penetration at 25°C (77°F) of a sample of grease in its container with no disturbance. Typical uses of the undisturbed penetration are: (1) to control the consistency of certain greases during manufacture, and (2) to assess the degree to which a grease develops a false body or set upon prolonged storage. The use of undisturbed penetration as a quality control test does not involve the transfer of grease samples from one container to another prior to testing. However, in evaluating the effect of prolonged storage upon a lubricating grease, samples may be

repackaged prior to storage in an appropriately sized container. Parties interested in measuring the undisturbed penetration on grease samples should use the general procedure in accordance with 11.1 only (not the repeat determinations described in 11.1.1) and establish mutually agreeable conditions for storage and container size.

X1.1.1 For undisturbed penetration, normally only a single determination can be made on a specimen as the action of dropping the cone, withdrawing it and repairing the grease surface results in mechanical shear that may change the

consistency of the grease and the penetration value that would be obtained from a repeat determination. This is the difference between *Undisturbed Penetration* and *Unworked Penetration*.

SUMMARY OF CHANGES

Subcommittee D02.G0 has identified the location of selected changes to this standard since the last issue (D217–02(2007)) that may impact the use of this standard.

- (1) Added new **1.1.3** to recommend use of worked penetration to measure grease consistency.
- (2) Revised **4.1** to clarify general technique for measuring unworked penetration.
- (3) Revised **6.5** to describe options for bringing the grease sample and test equipment to test temperature.
- (4) Reorganized and revised **8.1** and **8.2**, including subsections to standardize sample size for each test method and sample preparation and retention techniques with the revised test protocol.
- (5) Revised Section **10** to increase flexibility of calibration testing.
- (6) Revised and reorganized Section **11** to specify that 3 measurements are now obtained on a single specimen.
- (7) Revised **12.1.1** and **12.1.4** to be consistent with renumbering of earlier sections.
- (8) Updated Section **13** to include reference to new Research Report.
- (9) Revised **Table 1** to include updated precision data.
- (10) Revised **Appendix X1** to clarify that only 1 measurement per specimen can be made for Undisturbed Penetration.

ASTM International takes no position respecting the validity of any patent rights asserted in connection with any item mentioned in this standard. Users of this standard are expressly advised that determination of the validity of any such patent rights, and the risk of infringement of such rights, are entirely their own responsibility.

This standard is subject to revision at any time by the responsible technical committee and must be reviewed every five years and if not revised, either reapproved or withdrawn. Your comments are invited either for revision of this standard or for additional standards and should be addressed to ASTM International Headquarters. Your comments will receive careful consideration at a meeting of the responsible technical committee, which you may attend. If you feel that your comments have not received a fair hearing you should make your views known to the ASTM Committee on Standards, at the address shown below.

This standard is copyrighted by ASTM International, 100 Barr Harbor Drive, PO Box C700, West Conshohocken, PA 19428-2959, United States. Individual reprints (single or multiple copies) of this standard may be obtained by contacting ASTM at the above address or at 610-832-9585 (phone), 610-832-9555 (fax), or service@astm.org (e-mail); or through the ASTM website (www.astm.org). Permission rights to photocopy the standard may also be secured from the Copyright Clearance Center, 222 Rosewood Drive, Danvers, MA 01923, Tel: (978) 646-2600; <http://www.copyright.com/>